

Safesign (LED, Fluorescent and Halogen lamp) Illuminated Airfield Guidance Signs Manual



Note: *This page is blank for convenient double-sided printing.*

**SAFESIGN
 MANUAL
 CONTENTS**

Section	Description	Page No.
1.	INTRODUCTION	2
1.1	PRODUCT DESCRIPTION.....	2
1.2	SAFESIGN MODELS.....	2
1.3	SAFESIGN USE.....	2
1.4	SAFESIGN DIMENSIONS	2
1.5	DOCUMENTATION	3
2.	INSTALLATION.....	4
2.1	SITE PREPARATION	4
2.1.1	Mounting.....	4
2.1.2	Mounting Distances.....	4
2.1.3	Connection	5
2.1.4	Sign Electrical Specifications.....	6
2.2	STANDARD HARDWARE	8
2.2.1	Before you start	8
2.2.2	Install with Standard Hardware	9
2.3	PRECAST CONCRETE, LAMP POST FOUNDATIONS.....	10
2.3.1	Before you start	10
2.3.2	Install using precast concrete, lamp post foundations	11
3.	OPERATION.....	12
4.	MAINTENANCE	13
4.1	BIRD DETERRENT (OPTION)	13
4.1.1	Install a bird deterrent (option).....	13
4.2	ADJUSTMENT OF THE CLAMPS.....	14
4.2.1	Adjustment of the positions of the clamps.....	14
4.2.2	Adjustment of the pressure in clamps.....	14
4.3	SPARE PARTS.....	15
5.	DRAWINGS	18
5.1	CONNECTION DIAGRAMS.....	18
5.1.1	Series Power LED tube (single LED tube).....	18
5.1.2	Series Power LED tube (double LED tube)	19
5.1.3	Parallel Power LED tube (single LED tube).....	20
5.1.4	Parallel Power LED tube (double LED tube)	21
5.1.5	Series Power Fluorescent Lamp Signs, Single 36 W or 58 W Lamp. .	22
5.1.6	Series Power Fluorescent Lamp Signs, Double 36 W or 58 W Lamps	23
5.1.7	230 V Power, Fluorescent Lamp Signs, Single 36 W or 58 W Lamp...	24
5.1.8	230 V Power, Fluorescent Lamp Signs, Double 36 or 58 W Lamp.....	25
5.1.9	Series Power Halogen Lamp Signs.....	26

1. INTRODUCTION

1.1 PRODUCT DESCRIPTION

Safesign illuminated airfield guidance signs are used as information, position and direction indicators in accordance with *ICAO Annex 14, Section 5.4 Signs*.

These signs also meet the current standards for EMC Emission and Immunity and have an IP64 ingress classification.

Note: *This manual describes Safesign models in the product family number 597503.*

Sign construction includes a housing made from aluminium and a display front of UV-resistant polycarbonate plastic.

1.2 SAFESIGN MODELS

There are five different sign models according to power and light source requirements.

Power	Light
1. Constant Current Regulator (Series Fed)	Current range 2.8 - 6.6 A 18, 25 or 28W LED tubes
2. Mains Power System (Parallel system)	Voltage range 120–240VAC, 50/60Hz 18, 25 or 28W LED tubes
3. Constant Current Regulator (Series Fed)	Current range 2.8 - 6.6 A 36 or 58W Fluorescent tubes
4. Constant Current Regulator (Series Fed)	Current range 2.8 - 6.6 A 45 W Halogen lamps
5. Mains Power System (Parallel system)	Voltage range 230–240 VAC 36 or 58W Fluorescent tubes

1.3 SAFESIGN USE

Signs are designed for use in areas according the temperature range requirements of the light sources.

Light source	Temperature
LED	-25°C to 55°C
Fluorescent tubes	-25°C to 55°C
Halogen lamps	-55°C to 55°C

1.4 SAFESIGN DIMENSIONS

Signs are designed with the following standard dimensions:

Dimension	Measurement (mm)
Height	700, 900 (un-mounted sign only)
Width	1100, 1300, 1600, 1800, 2100, 2500, 2700 and 3000.

Note: *When installed, the total sign heights mounted on poles increases by 150 mm. The height of the front panel (visual plastic part) is 600mm (700mm sign height) and 800mm (900mm sign height)*

1.5 DOCUMENTATION

This document aims to give personnel an insight into the benefits of using Safesign Illuminated Airfield Signs and is a guide to general use that is logical and intuitive.

Copyright

© Copyright 2009 by Safegate Group. All rights reserved. This item and the information contained herein are the property of Safegate Group. No part of this document may be reproduced, transmitted, transcribed, stored in a retrieval system, or translated into any language or computer language in any form or by any means otherwise, without the expressed written permission of Safegate Group, Djurhagegatan 19, SE-213 76 Malmö, Sweden.

History

This document is revised according to version management for external use.

Version	Date	Description
1.0	September 2008	First release
1.1	June 2009	Second release
1.2	July 2009	Third release
1.3	October 2009	Fourth release
1.4	August 2011	Fifth release

Note: Safegate Group is responsible for providing updates, as available.

References and trademarks

Safesign is a trademark of Safegate International AB.

Other products and company names mentioned herein may be the trademarks of their respective owners.

Any rights not expressly granted herein are reserved. All illustrations and images are for illustration only and may not accurately depict the actual product.

Terminology

This document includes a selection of terms, words and abbreviations.

Term or word	Abbreviation	Comment
Airfield signs	AFS	
Airfield Smart Power SafeControl	ASP-SC	A Safegate Group solution.

Language

Original documentation is created in English (U.K.).

Note: Images and texts used in this document are reference examples only and may not exactly depict a customer product.

For more information, see www.safegate.com.

2. INSTALLATION

Sign installation is a relatively simple and straight forward process, once the location for the sign is properly prepared.

2.1 SITE PREPARATION

Some site planning and preparation is required before installation according to ICAO Annex 14 for example, requirements for placement near runways, taxiways and intersections, and requirements for mounting on solid, flat, level surfaces.

2.1.1 Mounting

Signs are delivered with mounting hardware including: poles, clamps, frangible couplings and mounting bases. The sign length determines the number of poles required (delivered) for installation. When installed, the total signs heights mounted on poles increases by 150 mm.

Sign width (mm)	No. of poles	Sign height (mounted on pole)
1100, 1300, 1600, 1800	2	700 (850) or 900 (1050)
2100, 2500, 2700	3	700 (850) or 900 (1050)
3000	4	700 (850) or 900 (1050)

2.1.2 Mounting Distances

Mounting distances between poles are dependent on the sign length. Bases for poles are installed on the surface of the sign location. The number of bases required is equal to the number of poles. Poles are mounted in bases.

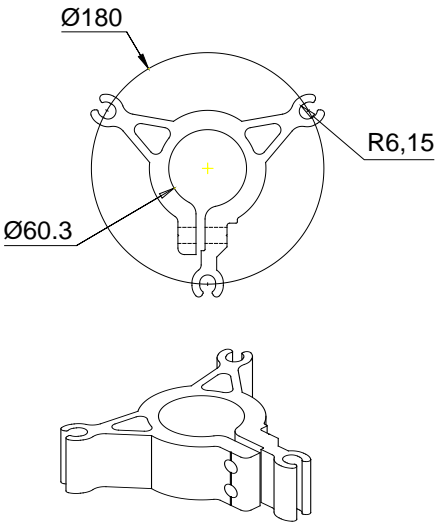
General recommendations, dimensions and appearance of mounting bases																			
<ol style="list-style-type: none"> The bases require three M12 anchor bolts to fasten them to the foundation. To mate with the base, the anchor bolts must be installed on a diameter of 180 mm with 120° spacing. Use the correct Centre to Centre (C-C) mounting distance to layout anchoring points on the surface according to the sign length and where the sign is to be installed. 																			
<table border="1"> <thead> <tr> <th>Sign Width (mm)</th> <th>C-C distances (mm)</th> </tr> </thead> <tbody> <tr><td>1100</td><td>700</td></tr> <tr><td>1300</td><td>900</td></tr> <tr><td>1600</td><td>1200</td></tr> <tr><td>1800</td><td>1400</td></tr> <tr><td>2100</td><td>850</td></tr> <tr><td>2500</td><td>1050</td></tr> <tr><td>2700</td><td>1150</td></tr> <tr><td>3000</td><td>867</td></tr> </tbody> </table>	Sign Width (mm)	C-C distances (mm)	1100	700	1300	900	1600	1200	1800	1400	2100	850	2500	1050	2700	1150	3000	867	
Sign Width (mm)	C-C distances (mm)																		
1100	700																		
1300	900																		
1600	1200																		
1800	1400																		
2100	850																		
2500	1050																		
2700	1150																		
3000	867																		

2.1.3

Connection

Signs are not supplied with external wiring unless specifically requested, as cabling requirements differ from site to site.

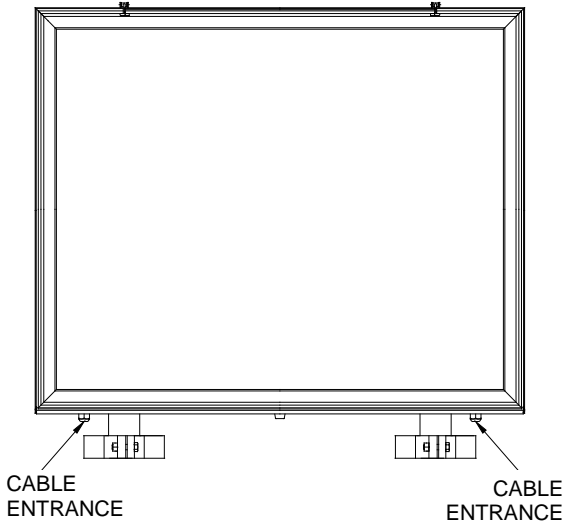
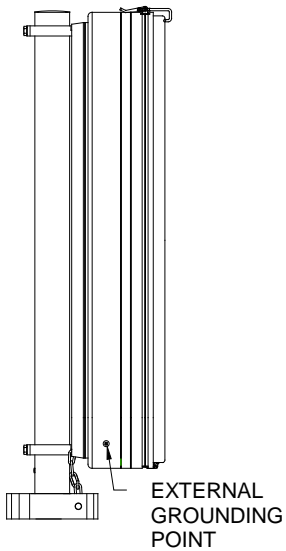
General recommendations for connection	
<p>It is recommended to consider the routing of external electrical cables to power signs, for example cable passages and junction boxes may need to be built into the foundations where signs are to be installed.</p> <p>Signs are designed with 2 entrance points for power cables to allow some flexibility for connection. These points are located on the bottom surface of the sign, 150 mm from each end. The cable glands at the entrance points accept cables between 7.5 and 14 mm in diameter.</p> <p>Connection terminals for the power cable are located next to each cable entrance.</p> <p>Note: <i>The larger halogen lamp signs that require two isolation transformers for operation have 4 cable entrances: two at each end of the sign.</i></p>	
<p>To ground a series fed sign after it is installed, attach a ring type crimp terminal to the ground wire and then fasten it to the side of the sign using the grounding screw (M6 Phillips head screws are located near the bottom of both ends of the sign).</p>	

2.1.4 Sign Electrical Specifications

Signs have electrical specifications according to LED, Fluorescent or Halogen lamp types for reference when planning installation.

2.1.4.1 Signs with LED tubes

Sign length (mm)	LED tubes (pcs)	Tube length (m)	LED tube rating (W)	Power consumption (W)	Recommended isolation transformer (W)
1100	1	0.97	1x 18	43	65
1300	1	1.20	1x 25	51	65
1600	1	1.50	1x 28	54	65
1800	2	0.97	2x 18	64	65
2100	2	1.20	2x 25	77	100
2500	2	1.20	2x 25	77	100
2700	2	1.50	2x 28	84	100
3000	2	1.50	2x 28	84	100

2.1.4.2 Signs with LED tubes (constant light output 100% between 2.8-6.6A)

This version is only available in limited market areas

Sign length (mm)	LED tubes (pcs)	Tube length (m)	LED tube rating (W)	Sign power consumption (W)	Recommended isolation transformer (W)
1100	1	0.97	1x 18	43	65
1300	1	1.20	1x 25	51	65
1600	1	1.50	1x 28	54	65
1800	2*	0.97	2x 18	89	100
2100	2*	1.20	2x 25	104	150
2500	2*	1.20	2x 25	104	150
2700	2*	1.50	2x 28	112	150
3000	2*	1.50	2x 28	112	150

*This version of sign contains 2 LED Power cassettes.

2.1.4.3 Signs with Fluorescent tubes

Sign width (mm)	Tubes (pcs)	Tube length (m)	Lamp rating (W)	Recommended isolation transformer (W)
1100	1	1.0	1x 36	65
1300	1	1.2	1x 36	65
1600	1	1.5	1x 58	65
1800	2	1.0	2x 36	150
2100	2	1.2	2x 36	150
2500	2	1.2	2x 36	150
2700	2	1.2	2x 36	150
3000	2	1.5	2x 58	150

2.1.4.4 Signs with Halogen Lamps

Sign width (mm)	Lamps (pcs)	Lamp Rating (W)	Recommended isolation transformers
1100	4	4x 45	1x 200W
1300	5	5x 45	1x 300W
1600	6	6x 45	1x 300W
1800	8	8x 45	2x 200W
2100	8	8x 45	2x 200W
2500	10	10x 45	2x 300W
2700	12	10x 45	2x 300W
3000	12	12x 45	2x 300W

2.2 STANDARD HARDWARE

2.2.1 Before you start

Standard tools are required, for example a socket set with a 15 cm or 6" extension bar.

Once site preparation is complete, the correct poles and frangible couplings must be identified for a sign installation.

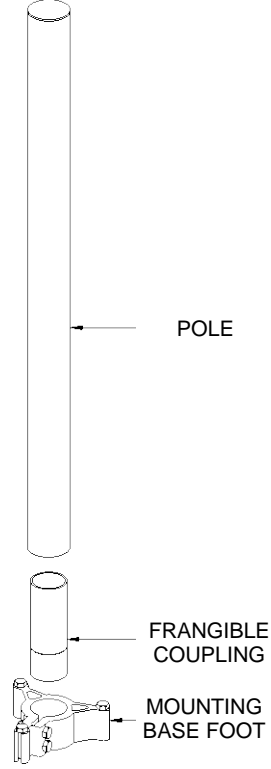
Poles and frangible couplings	Image example
<p>Poles with their respective frangible couplings are pre-assembled at the factory. All of the poles are shipped in the same crate. Before packing, the poles are packaged together in groups of 2, 3 or 4 poles to help indicate which sign they are to be used with.</p> <p>Since frangible couplings are not universal, this means there are different models that are intended to be used with different sign sizes. The label on the frangible coupling must be checked to make sure that it is installed with the correct size sign.</p> <p>An example of the pertinent information to check appears on the label as follows: For Sign(s) SG597503 (718), (727), (911). The numbers in the parentheses indicate the sign sizes that the frangible couple can be used with, and in this example they are: <u>700x1800</u>, <u>700x2700</u> and <u>900x1100</u>.</p> <p>The image example shows the relation between the pole, the frangible coupling and the mounting base/foot.</p> <p>Note: <i>The pole and frangible coupling are pre-assembled before delivery.</i></p>	 <p>The diagram illustrates the components of the hardware. It shows a long, thin cylindrical pole. Below the pole is a shorter, wider cylindrical frangible coupling. At the bottom is a mounting base foot, which is a complex mechanical component with a circular base and several mounting points. Arrows point from the labels 'POLE', 'FRANGIBLE COUPLING', and 'MOUNTING BASE FOOT' to their respective parts in the diagram.</p>

2.2.2 Install with Standard Hardware

1. Install the mounting bases and poles for the sign.
 - If the tethering chain is to be used, place the end link over one of the anchor bolts before installing the anchor bolt nut.

Note: Do not tighten the fasteners completely, as the poles may need to be adjusted slightly to line up with the mounting flanges on the sign.

2. Mount clamps with notches facing downwards, approximately halfway up each pole. Hand-tighten the set screws on the clamps.
3. Make a mark on one of the mounting poles, approximately 25 mm from the top. Install an upper clamp with its top surface in line with the mark on the mounting pole.
Note: This clamp is installed with its notches facing upward.

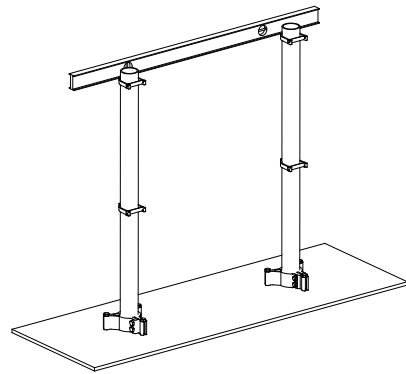

4. Install mounting clamps on the remaining poles. Use a spirit level or other levelling device to locate the upper clamps at the same height as the first clamp.
Note: The orientation of these clamps is also with the notches facing upward.
5. Lift the sign into position on the upper clamps.
Note: The poles may need to be adjusted so that the notches in the clamps line up with the mounting flange on the back of the sign.
6. With the sign hanging on its upper mounting flange, loosen one of the lower clamps on a pole and slide the clamp into position until it mates with the lower mounting flange on the sign. Tighten the set screw on the clamp until the bracket slightly shapes to the contours of the pole.
Note: Do not over tighten.
7. Slide each of the remaining clamps, one at a time, downward until they mate with mounting flanges and tighten each set screw.
8. Fasten the loose end of the tethering chain to the sign by attaching the spring clip to the bottom mounting flange at the nearest hole.

9. Tighten all fasteners holding the base plate against the installation surface. The finished assembly should have the same appearance as the sign shown in the image example.
10. Run the power cable through the cable gland.
11. Open the sign and attach the leads to the appropriate terminal contacts.
Note: If series fed, fluorescent lamp signs to be used in a lighting system controlled by a Safegate ASP-SC system, a converter filter (Safegate Group part no. 590591) needs to be installed in each sign. Installation instructions are supplied with the filter.
12. Tighten the cable gland.
13. Energise the power circuit to which the sign is connected and check for proper operation.

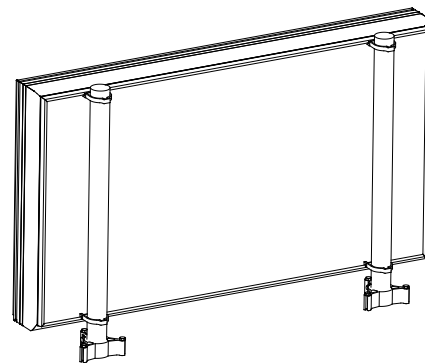

2.3 PRECAST CONCRETE, LAMP POST FOUNDATIONS

Note: (Scandinavia only)

2.3.1 Before you start

Once site preparation is complete, the correct poles and frangible couplings must be identified for a sign installation.

Note: This solution is only available in Scandinavia.

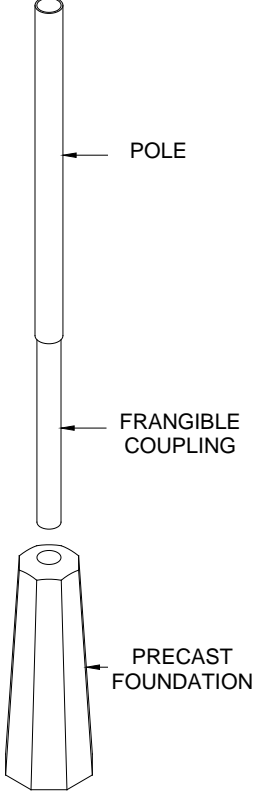
Poles and frangible couplings	Image example
<p>Poles with their respective frangible couplings are pre-assembled at the factory. All of the poles are shipped in the same crate. Before packing, the poles are packaged together in groups of 2, 3 or 4 poles to help indicate which sign they are to be used with.</p> <p>Since frangible couplings are not universal, this means there are different models that are intended to be used with different sign sizes. The label on the frangible coupling must be checked to make sure that it is installed with the correct size sign.</p> <p>An example of the pertinent information to check appears on the label as follows: For Sign(s) SG597503 (718), (727), (911). The numbers in the parentheses indicate the sign sizes that the frangible couple can be used with, and in this example they are: 700x1800, 700x2700 and 900x1100.</p> <p>In Scandinavia, the signs can be delivered with frangible couplings that can be used in pre-cast concrete, lamp post foundations, as in the image example.</p> <p>Note: For these installations the standard Y-shaped mounting base is not used and is therefore not supplied.</p>	 <p>The diagram illustrates the components of a pre-cast concrete lamp post foundation. It shows a vertical pole with a frangible coupling joint. Below the pole is a precast foundation base. Labels with arrows point to the 'POLE', 'FRANGIBLE COUPLING', and 'PRECAST FOUNDATION'.</p> <p>Note: A pre-cast foundation is not supplied.</p>

Pre-cast foundation

Pre-cast foundations and their collar shims are not included as part of the sign assemblies, if required they must be ordered separately using both the following article numbers 060 0700 (concrete foundation) and 301 0061 (collar).

The frangible couplings are only designed to be used with foundations that accept 60 mm diameter pipe and have an insertion depth for the pipe of 625 mm.

2.3.2 Install using precast concrete, lamp post foundations

Note: This solution is only available in Scandinavia.

1. Prepare the holes where the lamp post foundations are to be placed in accordance the manufacturer's instructions and with depths that prevent frost heaving.
2. Space the foundations according to the centre to centre pole spacing distances. For more information, see 2.1.2 Mounting Distances, step 4.
3. Make sure that the tops of the foundations are level with each other after insertion in the holes.

4. Make sure the centres of the foundations are in line with each other. To aid this alignment:

- (a) Install a pole assembly in each of the foundations and adjust the foundations so that the poles are vertical and in a straight line with each other.
- (b) Check the positions of the break-off points on the pole assemblies are within 5 mm of being at the same level with each other, they must not be positioned more than 50 mm above surface of the ground.
- (c) If necessary remove the pole assemblies and cut off excess material from each assembly so that break-off points are positioned correctly.
- (d) When removing the pole assemblies, carefully mark the positions of the alignment rings and collars that hold the assemblies in place. Do this to assure that the poles have the correct alignment when they are re-installed in the foundations.

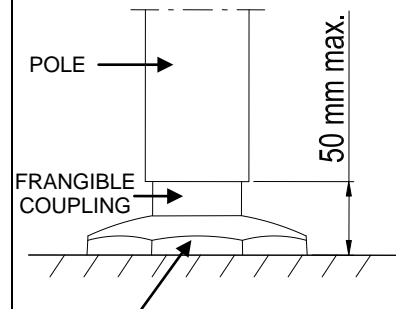

Foundation
Maximum height of break off point from ground surface.

5. After the poles are aligned, refill and repack the earth around the foundations. Make sure not to disturb the pole alignment when repacking and refilling.
6. Once the foundations are in place, re-check the positions of the break-off points on the pole assemblies.
7. Install mounting clamps on the remaining poles. Use a spirit level or other levelling device to locate the upper clamps at the same height as the first clamp.
Note: The orientation of these clamps is also with the notches facing upward.
8. Lift the sign into position on the upper clamps.
Note: The poles may need to be adjusted so that the notches in the clamps line up with the mounting flange on the back of the sign.
9. With the sign hanging on its upper mounting flange, loosen one of the lower clamps on a pole and slide the clamp into position until it mates with the lower mounting flange on the sign. Tighten the set screw on the clamp completely.
10. Slide each of the remaining clamps, one at a time, downward until they mate with mounting flanges and tighten each set screw completely.
11. Run the power cable through the cable gland and then tighten the cable gland.
12. Open the sign and attach the leads to the appropriate terminal contacts.
Note: If series fed, fluorescent lamp signs are to be used in a lighting system controlled by a Safegate ASP-SC system, a converter filter (Safegate Group part no. 590591) needs to be used with each sign.
14. Energise the power circuit to which the sign is connected and check for proper operation.

3. OPERATION

Safesign units are usually connected to the airfield power system and made available to other airport power control systems if required, for example Safegate ASP-SC.

Safesign units are easy to read in daylight, in darkness and with limited visibility. The high readability is a result of a high quality front panel, a unique screen painting technique and customized light distribution inside the sign. This is also combined with a robust aluminium construction, state-of-the-art electronics and an outstanding lifetime of the light sources, making a Safesign uniquely versatile and suitable for airport environments around the world.

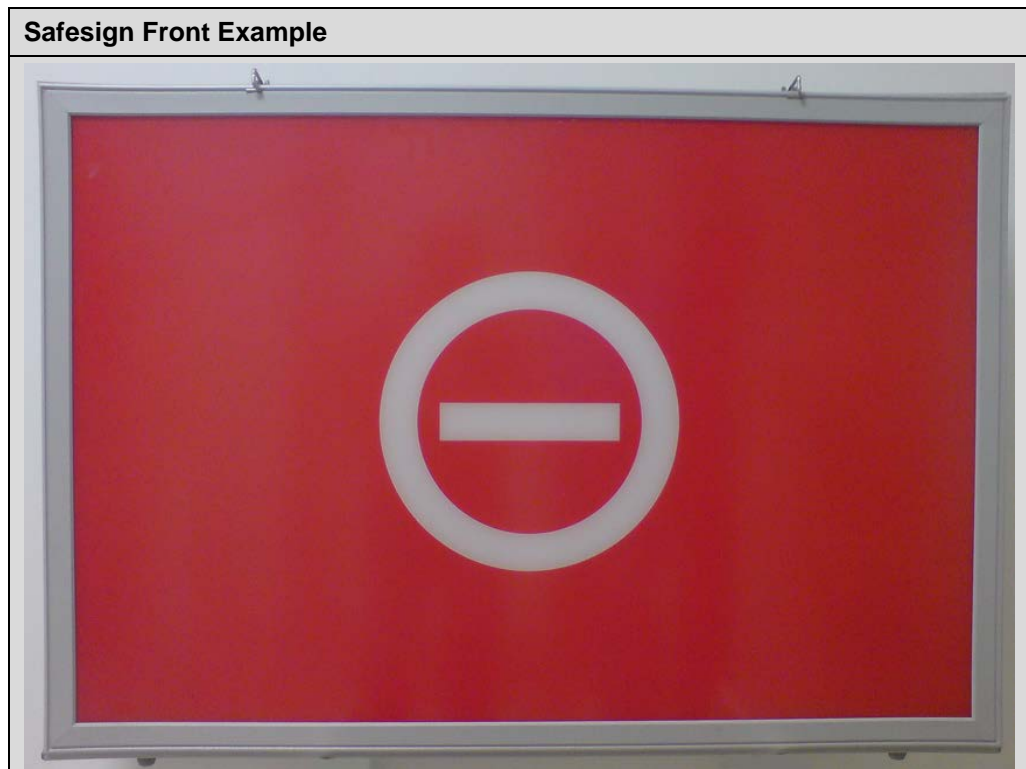

4. MAINTENANCE

Safesign units require minimal maintenance. It is recommended that a routine inspection is performed at least once a year with checks as follows:

- Damage to Sign front, housing and any exposed cabling.
- Weather gaskets are intact and prevent water or dirt from entering the sign.
- Tightness of all of the fasteners holding the sign securely in place.
- With the power off, check the terminal contacts to make sure the power cable wiring is securely fastened.

4.1 BIRD DETERRENT (OPTION)

Material for installing bird deterrent wires on the sign is available as an option.

The material consists of the following:

brackets, wire, screws for attaching the brackets to the sign and crimp fasteners for attaching the wire to the brackets.

4.1.1 Install a bird deterrent (option)	
<ol style="list-style-type: none"> 1. Attach one bracket at one end of the sign and tighten the mounting screws tightly. 2. Loosely attach the other bracket at the other end of the sign. 3. Place the crimp fasteners on the wire, but do not crimp them. 	
<ol style="list-style-type: none"> 4. Starting from the sign side of the firmly mounted bracket: <ol style="list-style-type: none"> (a) Feed one end of the wire through the hole in bracket. (b) Loop it around the bracket and then feed it back through the crimp fastener, as shown. 5. Slide the crimp fastener towards the bracket and crimp in place. 6. Repeat step 4 at the other end of the sign. 7. Apply tension to the wire so that the wire is tautly suspended between the two brackets. 8. Slide the crimp fastener towards the bracket and crimp in place. 9. Tighten the bracket's mounting screws. 	<p>Note: As seen from above.</p>

4.2 ADJUSTMENT OF THE CLAMPS

4.2.1 Adjustment of the positions of the clamps.

There is one clamp in front of each pole. The clamps are assembled in the aluminium profile. They can be moved sideways into the correct position.

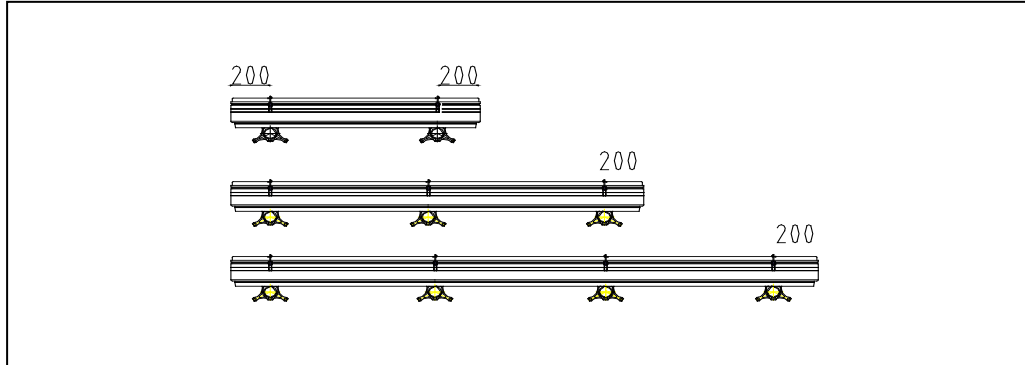

4.2.2 Adjustment of the pressure in clamps

When the gasket between the front panel and the sign frame is new, the distance A (as shown), is 4-5 mm.

- As the gasket ages, the elasticity decreases slightly and the clamps need to be adjusted to achieve a good water resistance in the sign.
- Tighten the clamps by rotating them 4-5 turns. Check the pressure of the clamps every time the sign is opened.

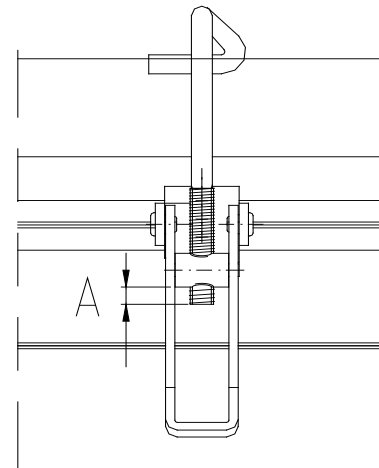

4.3 SPARE PARTS

Safesign is designed for ease of service with spare parts.

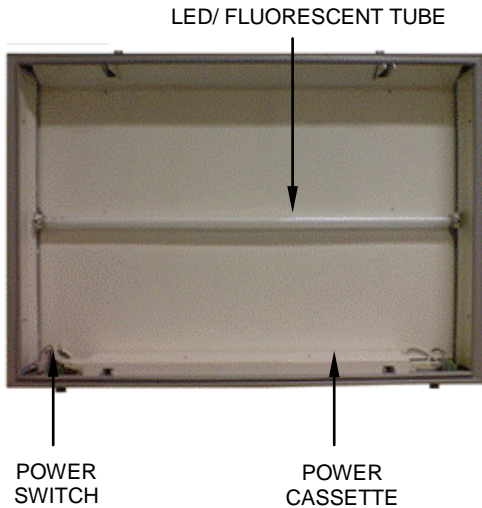
Safesign Spare Parts	Article Number	Image examples
LED tube		Sign (Front removed) 
LED tube 24VDC, 970mm	15960	
LED tube 24VDC, 1200mm	15961	
LED tube 24VDC, 1500mm	15962	
Fluorescent tube		
36W/840, WHITE, L = 1,0 m	14641	
36W/840, WHITE, L = 1,2 m	14640	
58W/840, WHITE, L = 1,5 m	14642	
Halogen lamp		
45 W, PK30d BASE	11991	
Film cut-out device 45-90W	15603	
Film cut-out G2 45-90W CAT 48159	10128	

Safesign Spare Parts	Article Number	Image examples
Power Switch		Power cassette LED/fluorescent tube, series system
230 V Signs	15331	
Series fed Signs	15332	
Complete Power Cassette (incl converter, transformer and connectors)		 <p>CONVERTER</p> <p>TRANSFORMER</p>
Power cassette LED 6.6A	15963	
Power cassette LED 230V	15964	
1x36 W, 230 V Fluorescent	13975	
1x58 W, 230 V Fluorescent	13976	
2x36 W, 230 V Fluorescent	13977	
2x58 W, 230 V Fluorescent	13978	
1x36 W, Series Fluorescent	13972	
1x58 W, Series, Single Lamp Fluorescent	13973	
2x36 W, Series, Double Lamp Fluorescent	13974	
Converter		Power cassette fluorescent tube, parallel system
Quicktronic Professional 230V QTP1x36	15327	
Quicktronic Professional 230V QTP1x58	15328	
Quicktronic Professional 230V QTP2x36	15329	
Quicktronic Professional 230V QTP2x58	15330	
Single Lamp, 36/58W, 2.8-6.6A	13632	
Double Lamp, 36/58W, 2.8-6.6A	13633	
Safesign LED converter 230V	15965	
Safesign LED converter 6.6A	15853	
Transformer		
For single lamp sign	13634	
For double lamp sign	13635	
Safesign LED transformer	15854	

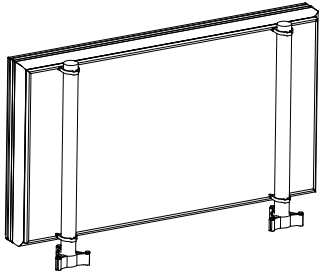
Safesign Spare Parts	Article Number	Image examples
Installation Material		
Mounting Base		
3 Bolt, Y-Shape	13993	
Poles		
700 mm high signs	13994	
900 mm high signs	13995	
Clamp	13996	

Frangible Couplings		
Sign Size	For 3 Bolt, Y-Shape, Mounting Base	For Pre-cast Foundation
700 x 1100 sign	13979	597503-256 (1,3)
700 x 1300 sign	13980	597503-256 (1,6)
700 x 1600 sign	13981	597503-256 (1,8)
700 x 1800 sign	13982	597503-256 (2,2)
700 x 2100 sign	13980	597503-256 (1,6)
700 x 2500 sign	13981	597503-256 (1,8)
700 x 2700 sign	13982	597503-256 (2,2)
700 x 3000 sign	13981	597503-256 (1,8)
900 x 1100 sign	13982	597503-256 (2,2)
900 x 1300 sign	13983	597503-256 (2,6)
900 x 1600 sign	13984	597503-256 (3,1)
900 x 1800 sign	13985	597503-256 (3,5)
900 x 2100 sign	13984	597503-256 (3,1)
900 x 2500 sign	13984	597503-256 (3,1)
900 x 2700 sign	13985	597503-256 (3,5)
900 x 3000 sign	13984	597503-256 (3,1)

When replacement frangible couplings are delivered, they need to be mounted in existing poles. Do this by inserting the end of the frangible coupling that is 150 mm from the break-off point, into the pole until the end of the pole is centred over the break off point of the frangible coupling.

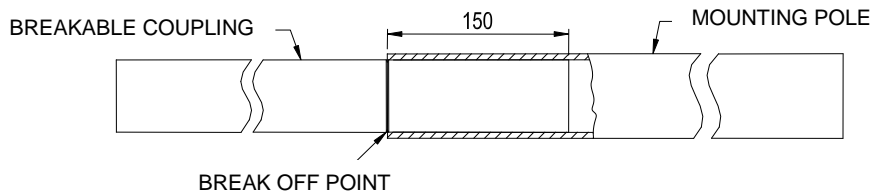

Fasten the two together using the self-drilling, self-threading screws that were supplied with the original assembly.

5. DRAWINGS
5.1 CONNECTION DIAGRAMS
5.1.1 Series Power LED tube (single LED tube)

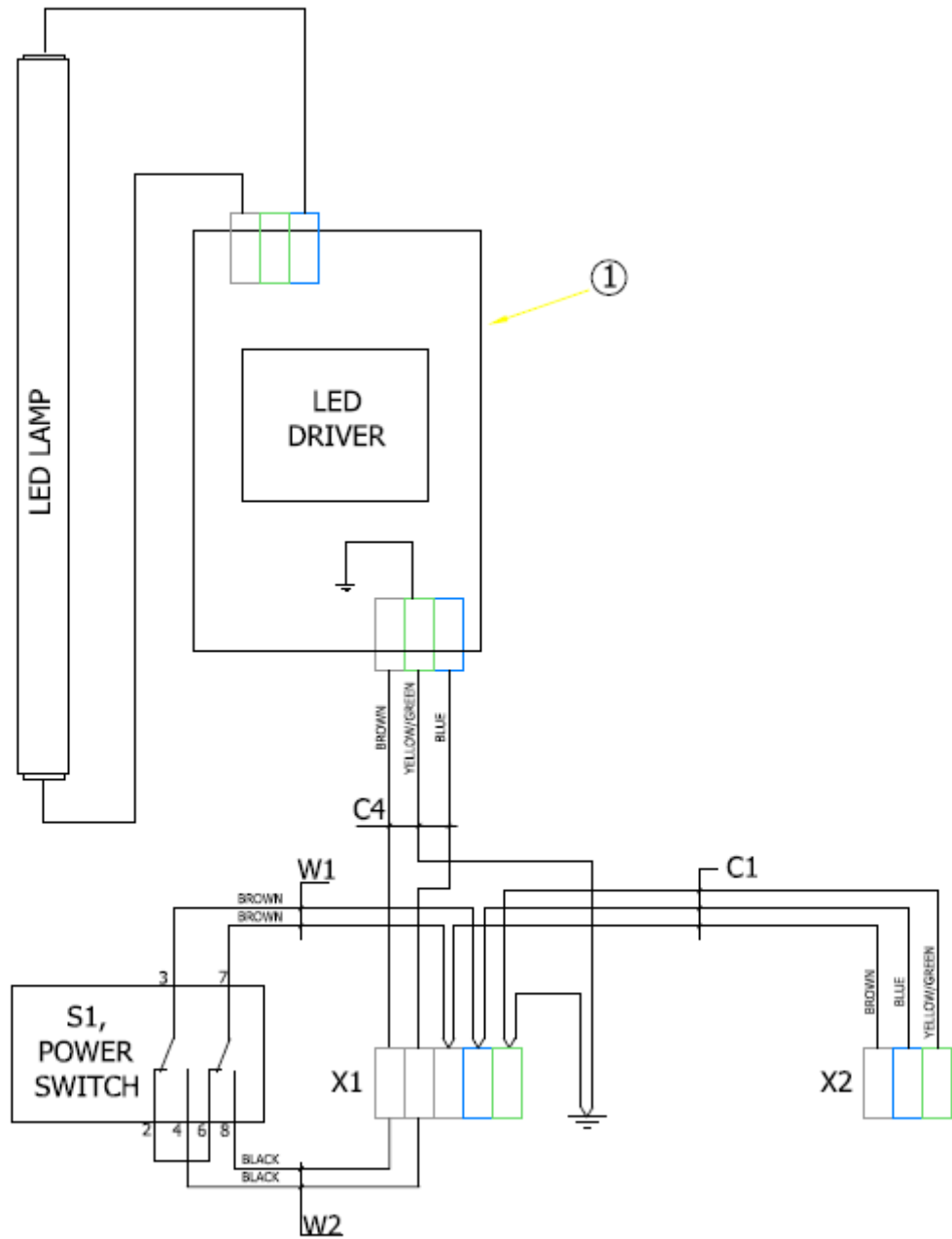

5.1.2 Series Power LED tube (double LED tube)

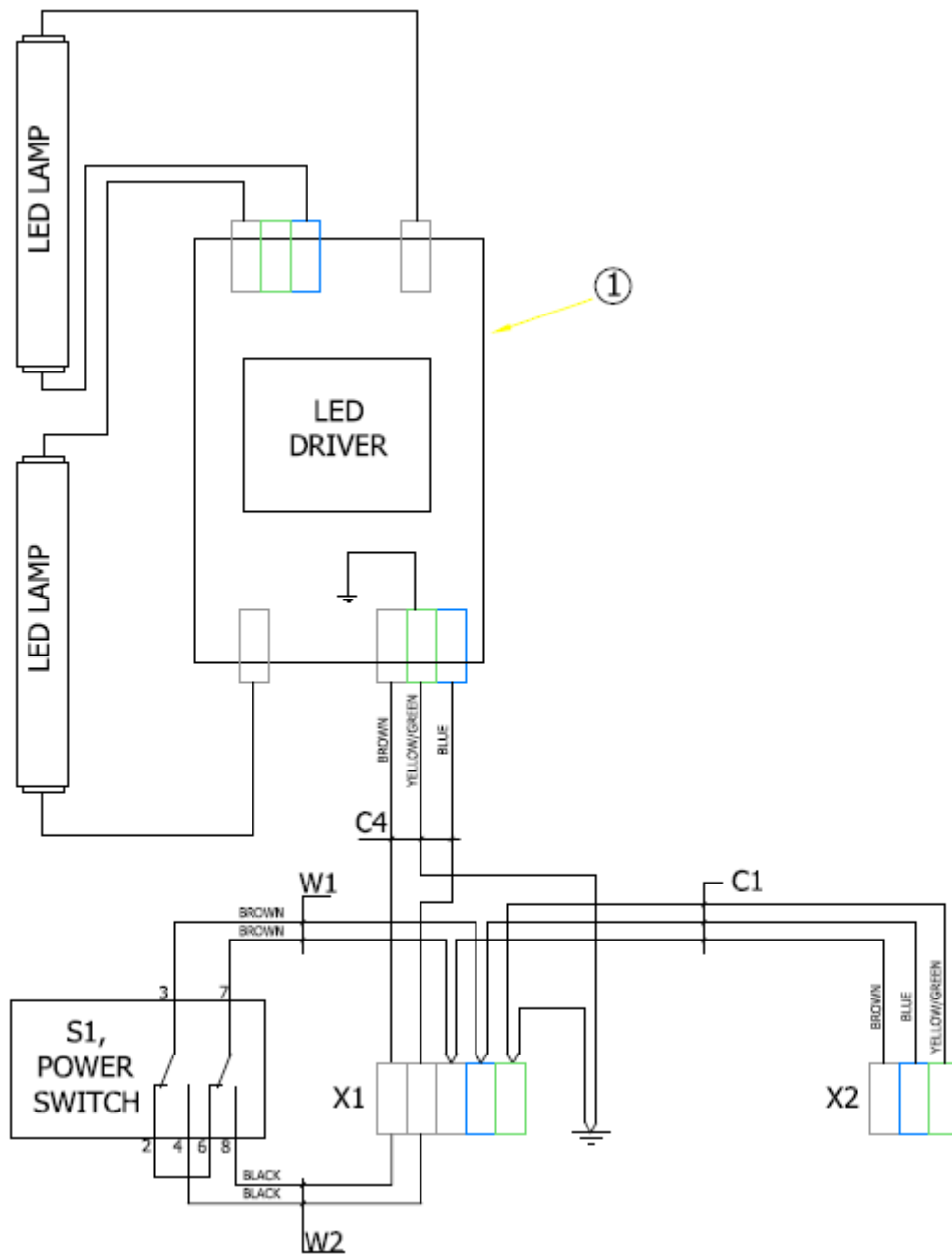

**Signs with constant light output 100% between 2.8-6.6A require double converters for the sign version 2100, 2500, 2700 and 3000mm. See chapter 2.1.4.2*

5.1.3 Parallel Power LED tube (single LED tube)

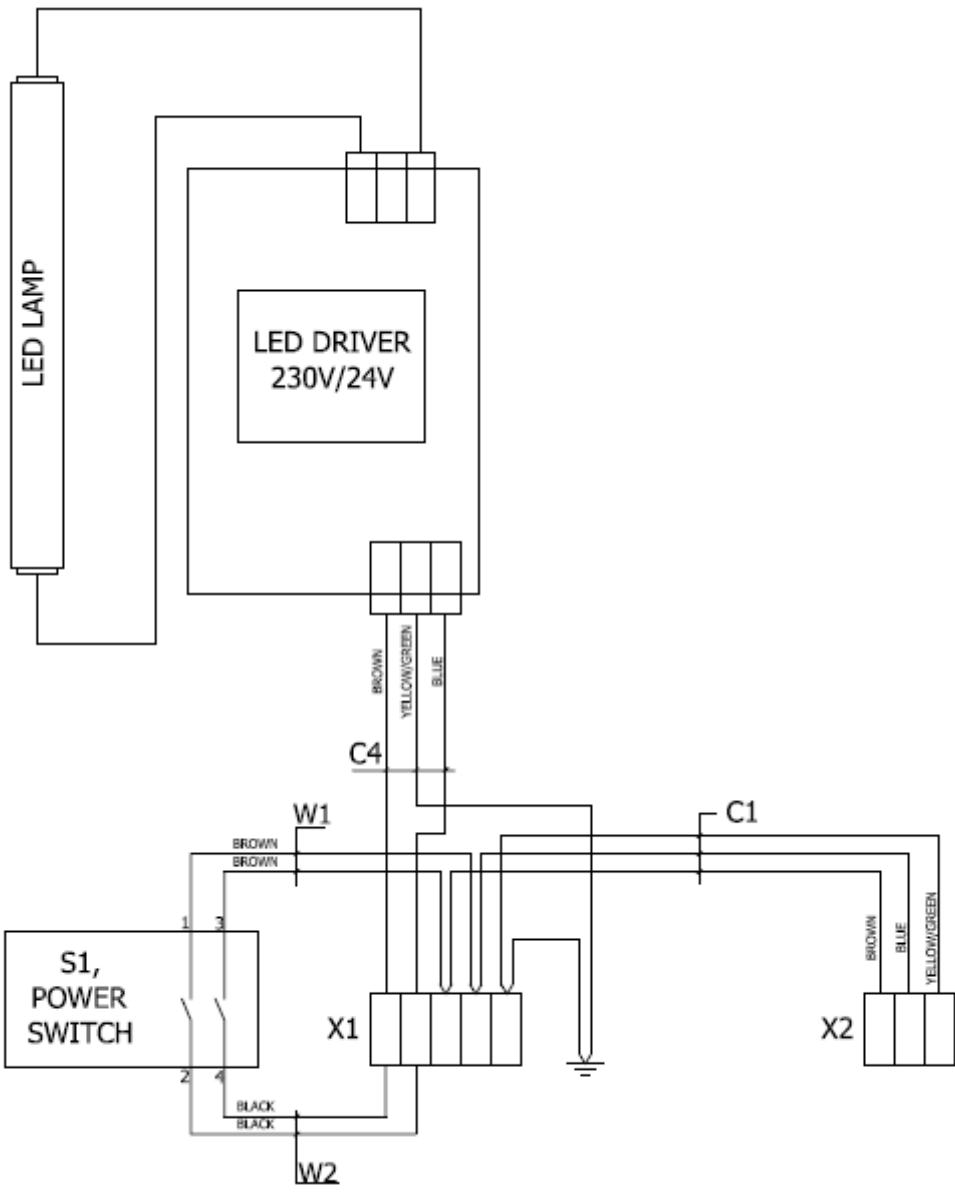

5.1.4 Parallel Power LED tube (double LED tube)

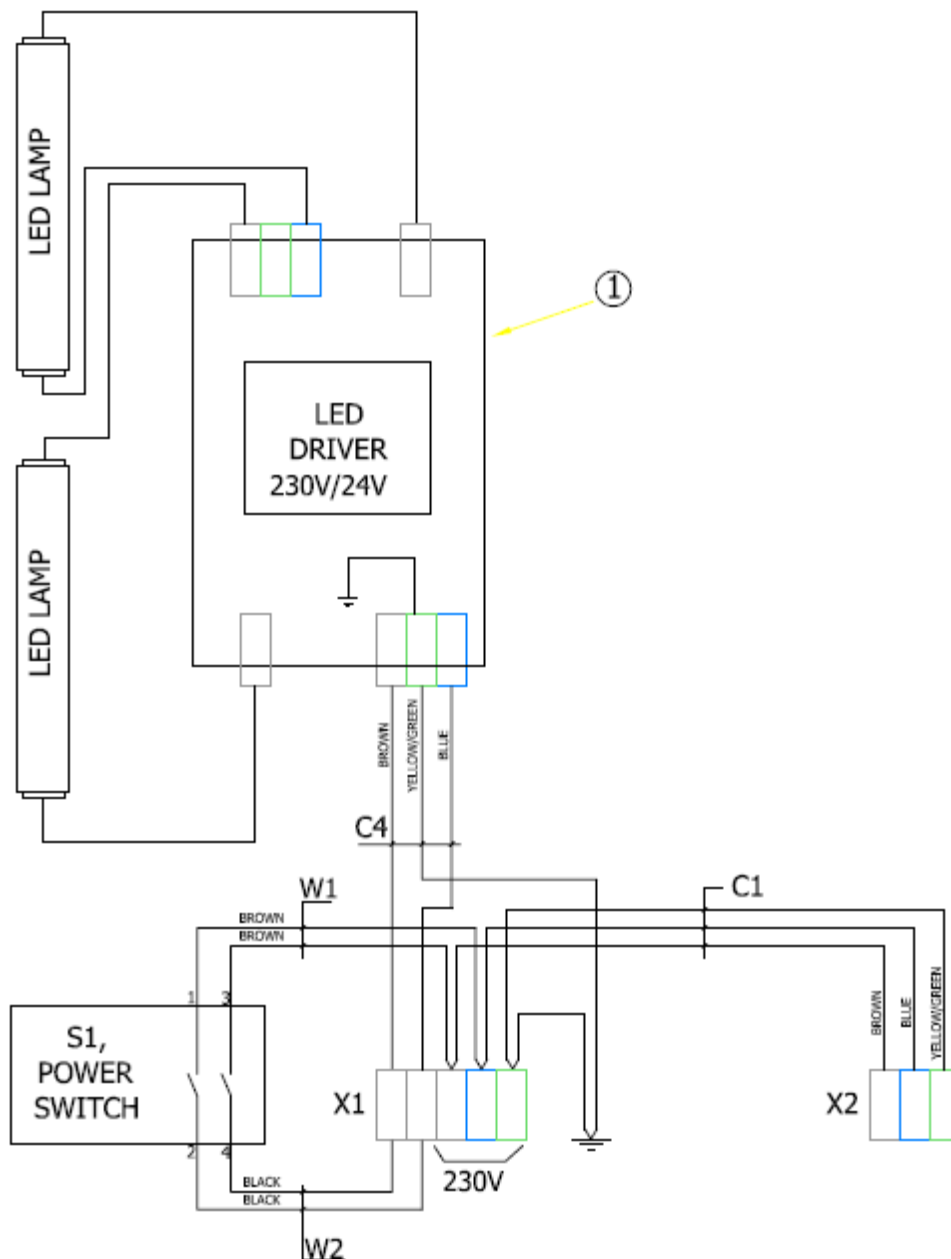

5.1.5 Series Power Fluorescent Lamp Signs, Single 36 W or 58 W Lamp.

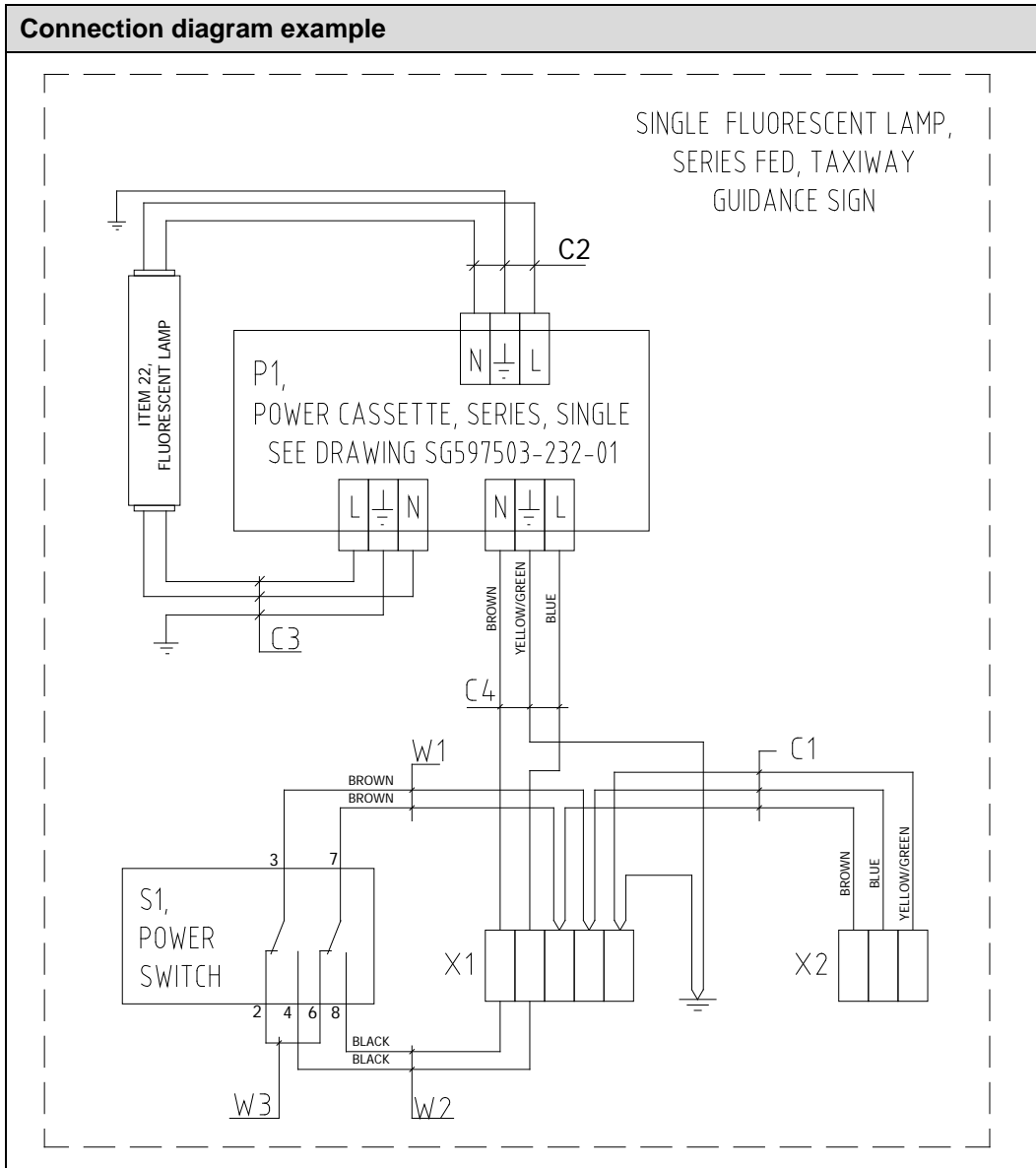

5.1.6 Series Power Fluorescent Lamp Signs, Double 36 W or 58 W Lamps

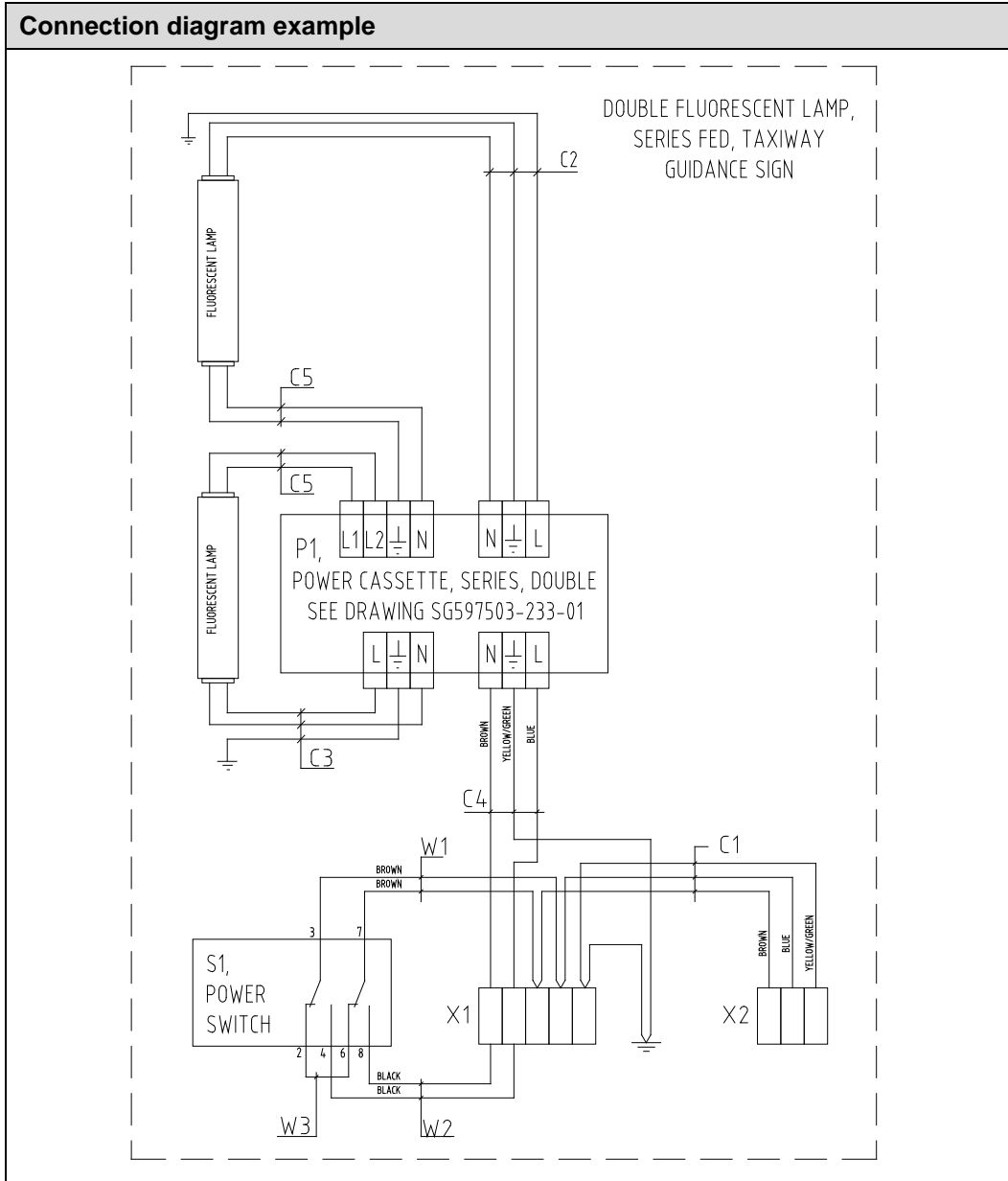

5.1.7 230 V Power, Fluorescent Lamp Signs, Single 36 W or 58 W Lamp

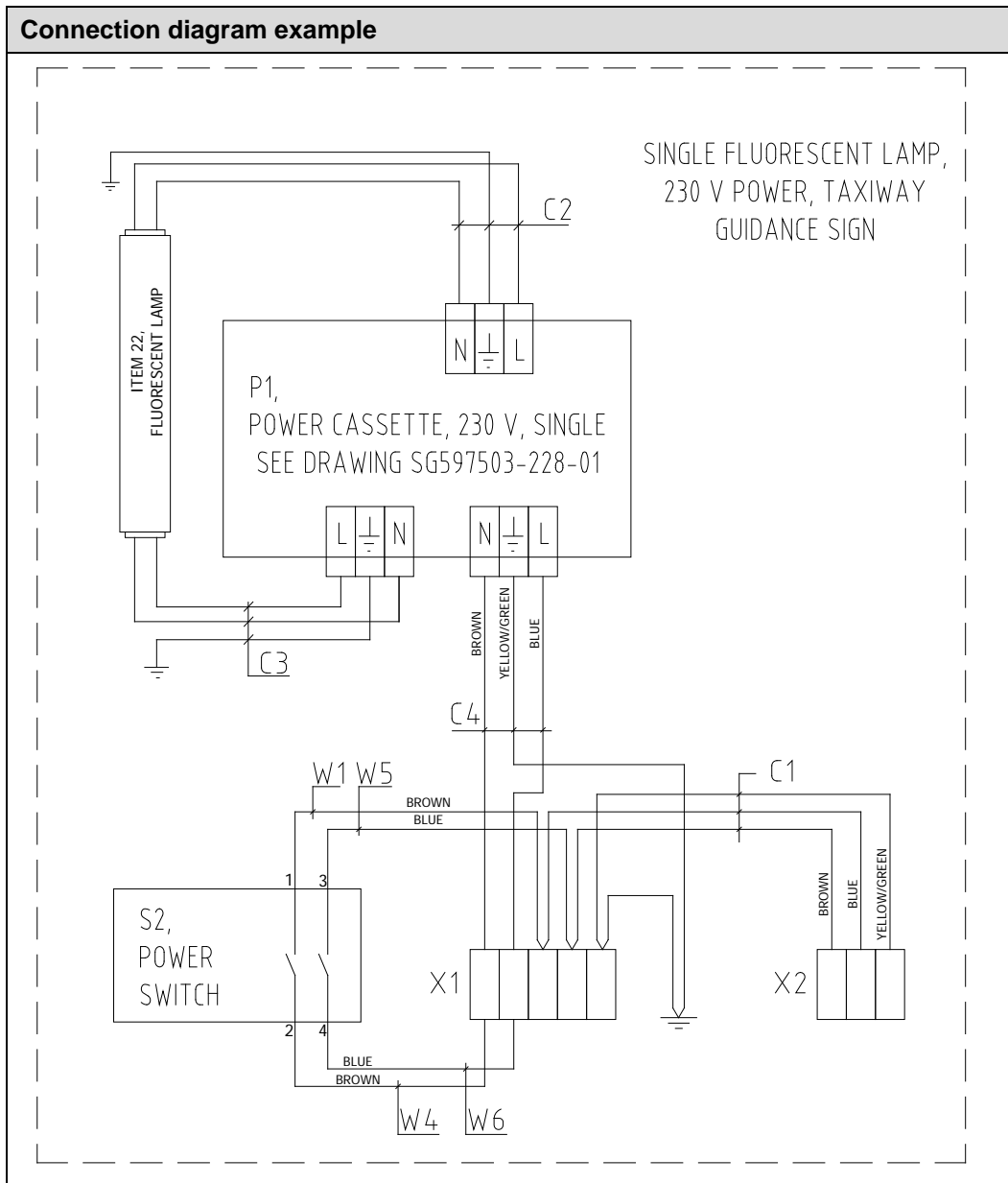

5.1.8 230 V Power, Fluorescent Lamp Signs, Double 36 or 58 W Lamp

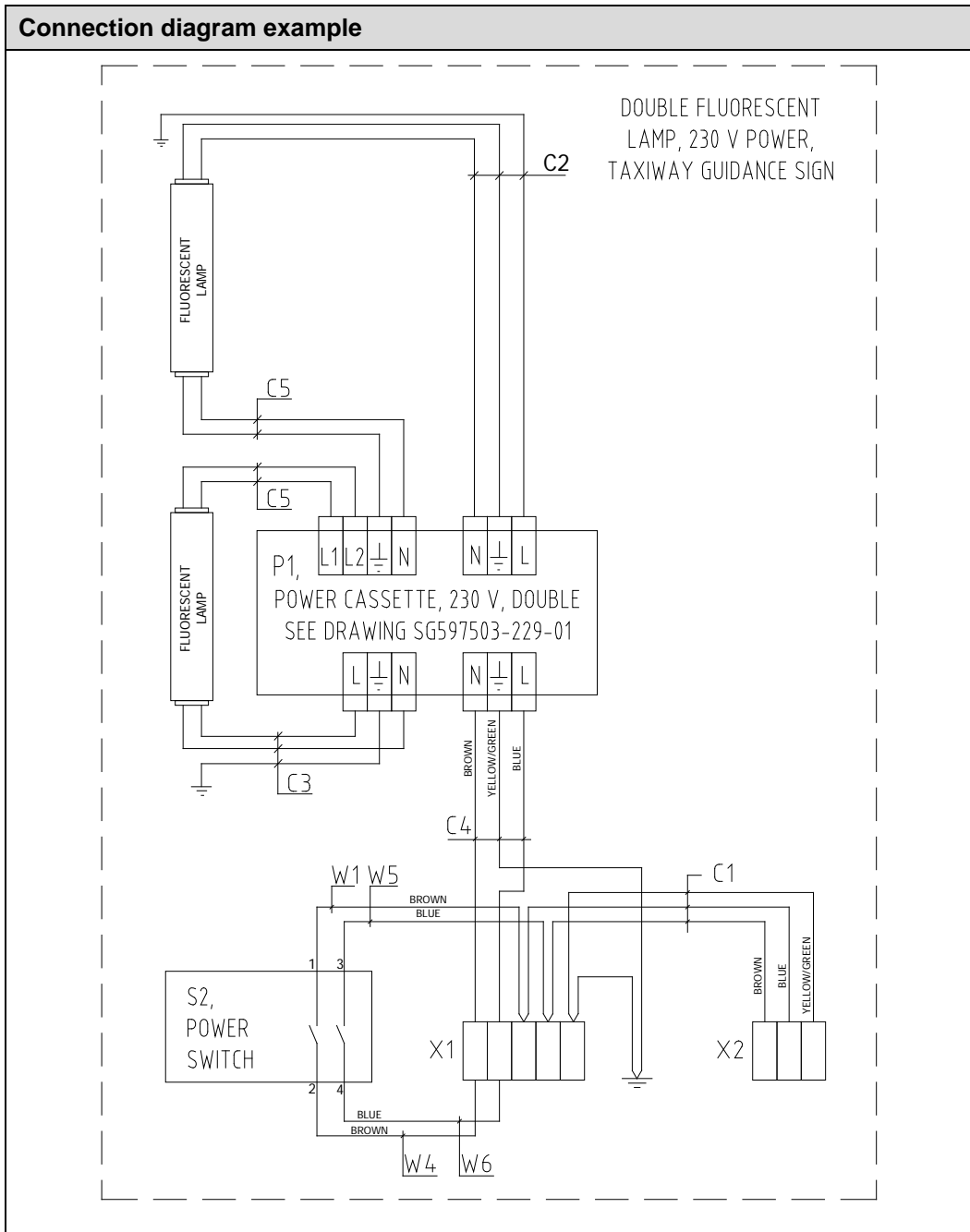

5.1.9 Series Power Halogen Lamp Signs

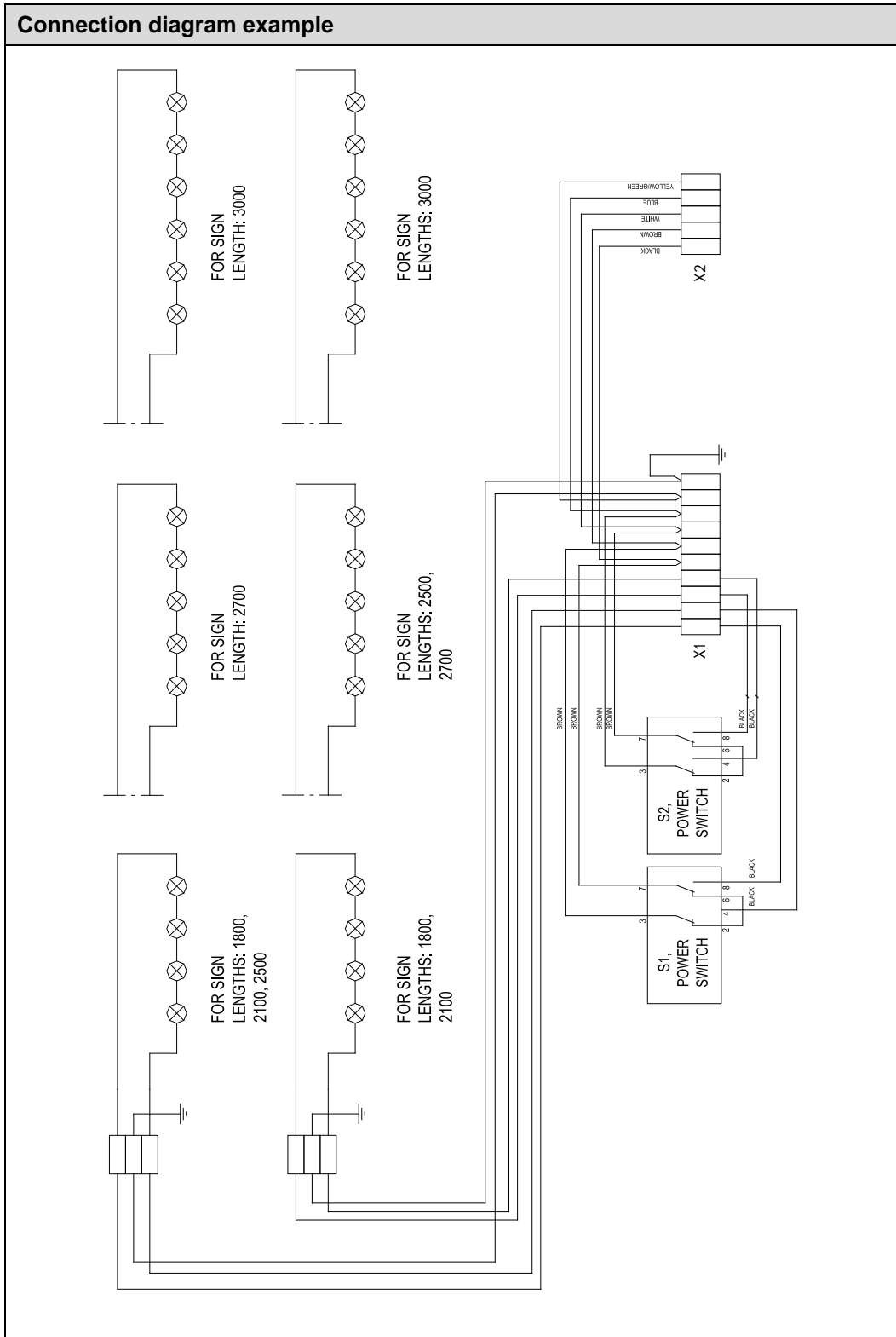

Note: *This page is blank for convenient double-sided printing.*

Check in to the future

How many aircraft can your airport handle today?
Can this number be increased without adverse effects on the airport's safety level?
It is a known fact that traffic volume will rise in the foreseeable future. More movements will demand monitoring of the entire airport. Requirements will be sharpened and the development of an integrated system

controlling not only ground movements but also air traffic close to the airport is of the highest interest.
The International Civil Aviation Organization (ICAO) already describes A-SMGCS, Advanced Surface Movement Guidance and Control System, as the answer to the future modern airport need to control the entire airport space in one superior system.

To a larger extent than today's systems, A-SMGCS will rely on automated processes to give both pilots and traffic controllers exact information about positions and directions. Safegate Group delivers complete A-SMGCS solutions already, as well as all vital parts relating to it. Safegate Group can check your airport into the future – today!



Safegate Group HO
Djurhagegatan 19
SE-213 76 Malmö, Sweden
Phone: +46 (0)40 699 17 00
Fax: +46 (0)40 699 17 30
E-mail: market@safegate.com

China
china@safegate.com
+8610-85275297

Dubai
dubai@safegate.com
+971 4 332 30 07

Australia
australia@safegate.com
+61 (0)3 9720-3233

Finland
finland@safegate.com
+358 (0)20754 7700

France
france@safegate.com
+33 (0)1 49 53 62 62

Germany
germany@safegate.com
+49 (0)231 9776754

India
india@safegate.com
+91 11 4106 1545

Malaysia
malaysia@safegate.com
+60 16 551 7126

Qatar
qatar@safegate.com
+974 436 9628

Russia
russia@safegate.com
+7 495 917 4614

Singapore
singapore@safegate.com
+65 6289 6893

Spain
spain@safegate.com
+34 917 157 598

UK
uk@safegate.com
+44 (0)208 573 0384

USA
usa@safegate.com
+1 763 535 92 99

THORN **IDMAN**
Airfield Lighting

SAFEGATE
GROUP 

Safegate Group offers solutions for increased safety, efficiency and environmental benefits to airports around the world. The company was founded in 1973 and has its headquarters in Malmö, Sweden. Safegate Group has over 70 partners around the globe in order to be close to its customers. The latest members of Safegate Group, Thorn AFL and Idman, have both over 40 years of experience in airfield lighting solutions for airports and heliports worldwide. Safegate Group's complete range of products and services, a "one-stop shop", provides solutions to customers and airborne travellers around the globe.

For more contact information and details:
www.safegate.com